

# STANDARD RANGE

1220mm PMMA Extrusion —  
SPICA & FIDIS

May, 2026

# Extrusion: presentation

**SPICA** and **FIDIS** are GAGGIONE's first slim, slide-in linear 1220mm length extruded optics, created for designers who shape spaces with light. Sharing the same optical philosophy and LED platform, they deliver two complementary architectural effects: SPICA: **wide, comfortable uplight/batwing (170°)** and FIDIS: **razor-sharp wall grazing beam (FWHM 12° x 75°)**



**SPICA**

Dimensions: 1220 mm x 19.9 mm x 6.10 mm

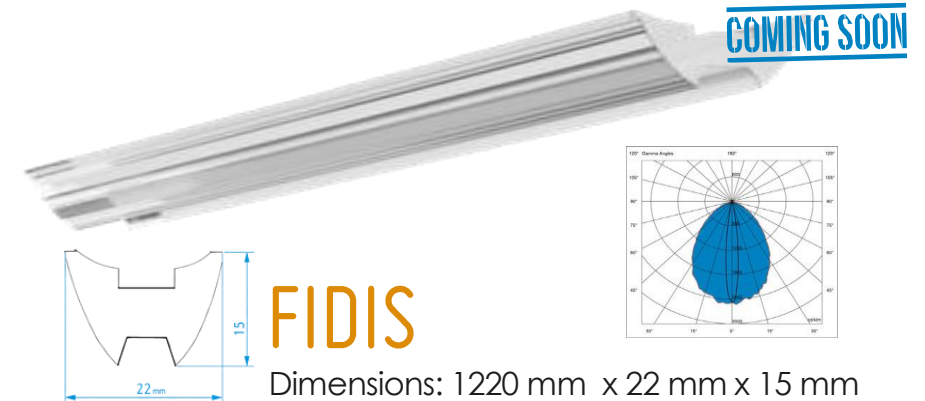

**FIDIS**

Dimensions: 1220 mm x 22 mm x 15 mm

### Application examples:

- Office (suspended luminaires, free standing luminaires)
- Architectural lighting
- Hospitality lighting
- Retail lighting (Refrigerators, freezers)

Type of Led	SPICA	FIDIS
CSP 3535 HP	✓	✓
2835 x 1 3030 x 1	✓	✓
Tunable White	✓	✓
RGBW	✗	✓

### Application examples:

- Hospitality (Office, hallways, hotel lobbies, reception areas)
- Architectural (Museums, Art galleries, show room)
- Accent lighting

# Extrusion: applications



Architectural



Museums



Hospitality



Supermarket



Office

# SPICA: 2D drawing

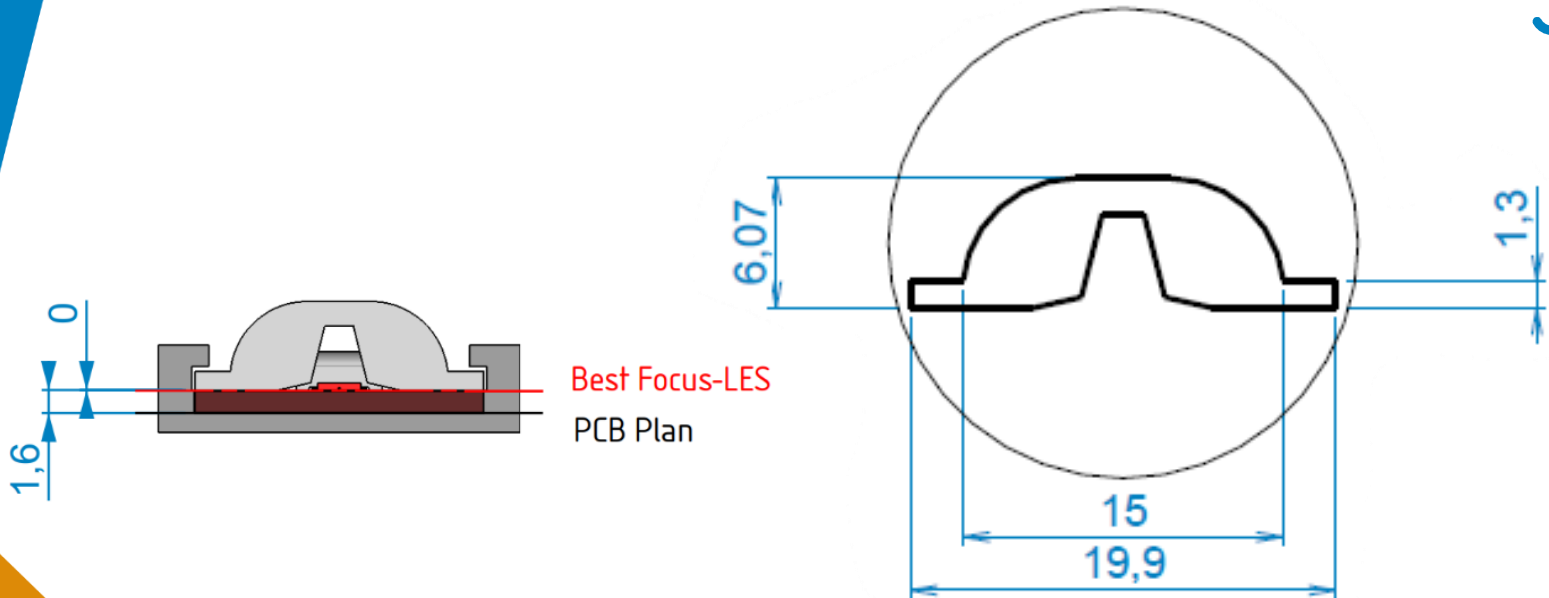

*\*\* Fixture design guide and PCBs available from STILEC  
Compatible also with most of the flexible LED strips \*\**

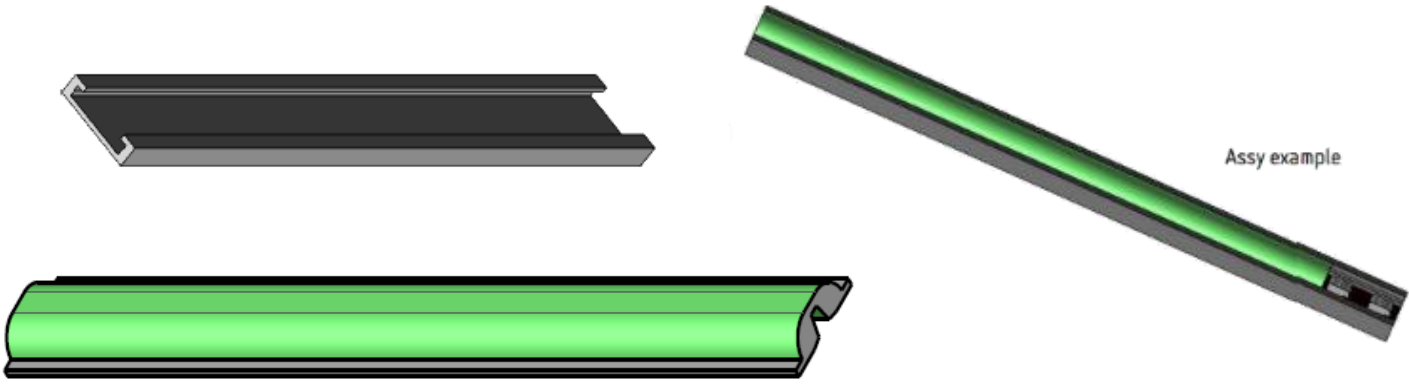
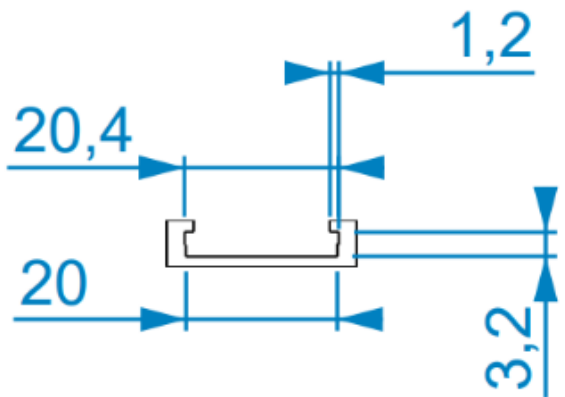

# SPICA: Batwing



## Compatibility matrix

SPICA	3030 package	
	Nichia 757	Lumileds 2835
FWHM (°)	119 x 43.7	18.2
FWTM (°)	169.5 x 182.8	28.7
Efficacy (cd/lm)	0.65	8

*\*\* Note, these are based on simulated results, please [contact us](#) for measurements, simulations and compatibilities for the LED type you would like to use.*

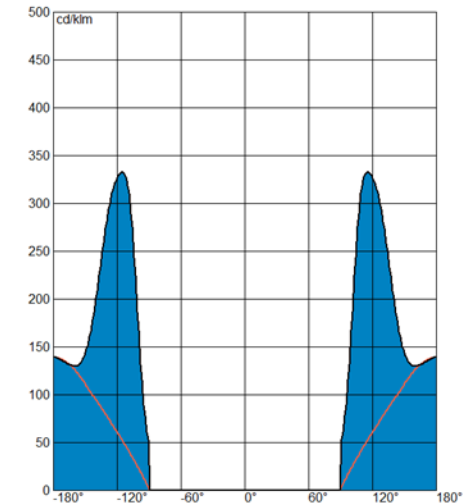
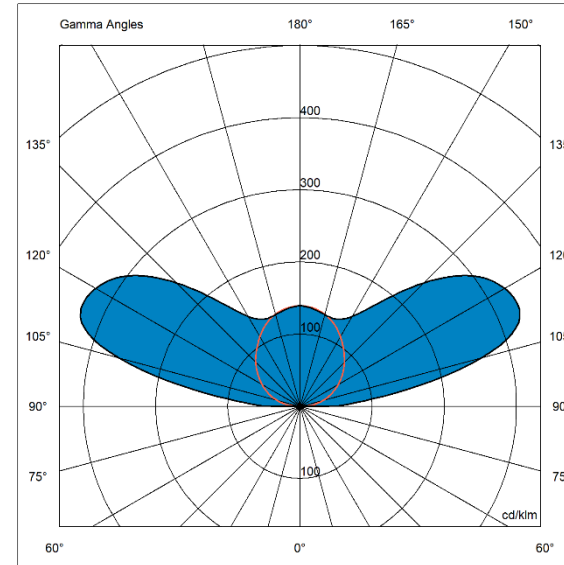

Intensity pattern  
LED: Nichia 757

[Visit the product page](#) on our website

## SPICA



- SPICA packing as follows:
- MPQ (Minimum packing quantity) = 25 pcs / parts are in PE bags.
- Quantity in box = 100pcs
- **Pallet sizes:**
- 1220pcs: 65 x 36H x 140 wooden pallet  
Weight: 120 kg  
Net weight (without wooden pallet): 103 kg
- 3050pcs: 65 x 40H x 265 wooden pallet  
Weight: 285 kg  
Net weight (without wooden pallet): 258 kg
- 10 004pcs 100 x 65H x 265 wooden pallet  
Weight: 885 kg  
Net weight (without wooden pallet): 845 kg
- 20 008pcs 100 x 65H x 265, 2pcs of wooden pallets  
Weight 880 kg per pallet  
Net weight: 1689 kg

# Extrusion: Packaging

# Code form standard range

## LENS

### OPTICAL

- 01: 16 mm
- 02: 16 mm
- 12: 16 mm
- 22: 16 mm RGBW
- 05: 32 mm
- 15: 32 mm
- 25: 32 mm RGBW
- 07: 35 mm
- 45: 45 mm UFO or VEGA
- 49: 45 mm RGBW
- 59: 45 mm RGBW gen 2
- 56: 67mm in PMMA
- 66: 67 mm in silicone
- 76: 67mm in silicone
- 67: 67 mm UFO

### PRODUCT

- LLC: Collimator
- LLH: Holder
- LLL: Linear collimator
- LLR: Reflector
- LLS: Set
- UFO: Ultra Flat Optic
- VEGA : 45mm COB oriented
- HADAR70: 70mm COB oriented
- POLLUX7X1: Linear low UGR solution
- AVIKA : Street Lighting

### BEAM ANGLE

- U/R/RF/UF: Ultra Narrow
- N/NF: Narrow
- M: Medium
- W: Wide
- X: Extra large
- S: Super large
- L: Large
- V: Very large
- E: Elliptical
- Z: Zoom

### MATERIAL

- 0 or nothing : PMMA
- 1: PC
- 2: PC anti-UV
- 7: Silicone

LLS01W01ABC001

**ABC:** Holder type according to LED package

### COLORS & DECORS

- 0: Translucent
- 1: White
- 2: Black

### ADHESIVE OPTION

- 1: Yes
- Nothing: No

### VERSION

### TYPE

- 1: 16mm
- 2: 32mm
- 3: 3x16mm
- 4: 4x16mm
- 9: 45mm

## HOLDER

# Contact us

## GAGGIONE SAS Headquarter

3, Rue de la Rolland  
01460 Montréal la Cluse  
France

☎ +33 4 74 76 12 66  
@ [contact@gaggione.com](mailto:contact@gaggione.com)  
🌐 [www.optic-gaggione.com](http://www.optic-gaggione.com)

## Sales Team in GAGGIONE

Sonia Andres  
Sales Director  
France, Italy, Spain

@ [s.andres@gaggione.com](mailto:s.andres@gaggione.com)  
☎ +33 607 37 20 28

Nicolas Golfier  
France, Scandinavia,  
Eastern and Northern Europe

@ [n.golfier@gaggione.com](mailto:n.golfier@gaggione.com)  
☎ +33 677 35 50 37

Thibaud Bourgeat  
UK, Eastern Europe

@ [t.bourgeat@gaggione.com](mailto:t.bourgeat@gaggione.com)  
☎ +33 688 03 59 51

## International Sales Offices

GAGGIONE Americas  
Michael Pietro  
12833 Surrey Ct.  
Palos Park, IL  
60464

@ [m.pietro@gaggione.com](mailto:m.pietro@gaggione.com)  
☎ +1 224 392 0087

GAGGIONE Canada & USA  
Stephane Saindon  
744 36th Avenue  
Montreal, Quebec  
H8T3L2

@ [s.saindon@gaggione.com](mailto:s.saindon@gaggione.com)  
☎ +1 514 928 2179

GAGGIONE Canada & USA  
Nicolas Pourrain  
744 36th Avenue  
Montreal, Quebec  
H8T3L2

@ [n.pourrain@gaggione.com](mailto:n.pourrain@gaggione.com)  
☎ +1 438 989 5133

GAGGIONE DACH  
Angelika Aigner  
Chieminger Strasse 12A  
83355 Grabenstätt  
Germany

@ [a.aigner@gaggione.com](mailto:a.aigner@gaggione.com)  
☎ +49 8661 983 44 77

GAGGIONE Asia  
Zhen Xu  
Unit 1808, No. 8, Kuaiji Road,  
Jintiandi International building,  
Huangpu District,  
Shanghai, 200021, China

@ [z.xu@gaggione.com](mailto:z.xu@gaggione.com)  
☎ +86 136 5189 6981

## Product Management & Business development

Joni MÄKI  
Artunkuja 7,  
24260 Salo  
FINLAND

@ [j.maki@gaggione.com](mailto:j.maki@gaggione.com)  
☎ +33 6 38 24 17 51



Newsletter



Linkedin