

D C B A

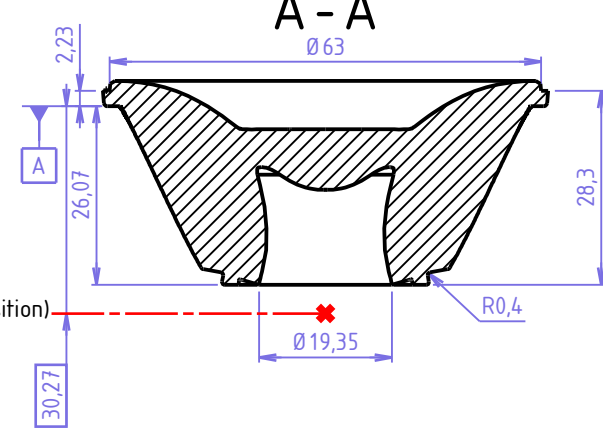

Injection Gate

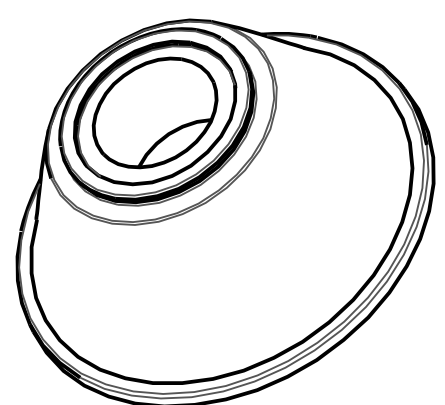
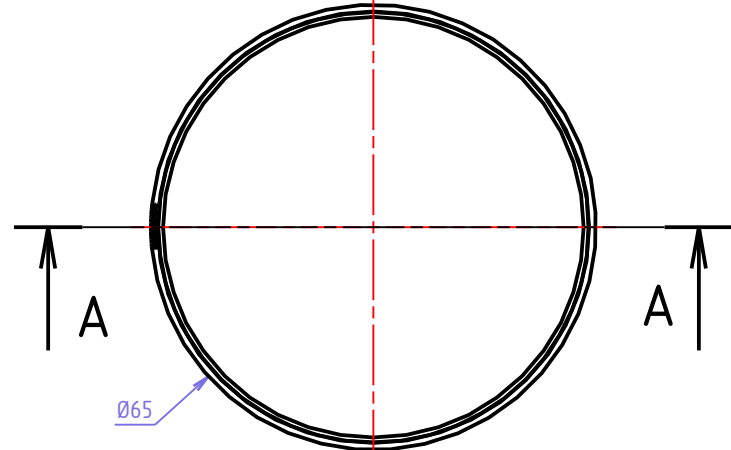
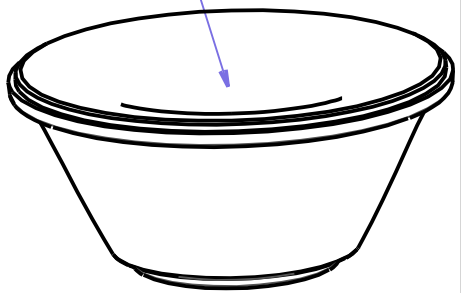

Welding line similar to initial samples  
 Frosting: Quantity 1, length 5mm max  
 Black dots: Quantity 4, size 0.1mm, distance between 2 points 50mm max  
 No burned parts, no impacts, no burrs  
 Roughness will be lower or equal to 15nm  
 Optical profile following design report n°OPT0156  
 General aspect: mirror polish

1	NARROW BEAM COLLIMATOR SH70	LLC76N7	LSR	
2	MEDIUM BEAM COLLIMATOR SH70	LLC76M7	LSR	
3	WIDE BEAM COLLIMATOR SH70	LLC76W7	LSR	
N°	NOM ARTICLE	CODE ARTICLE	MATIERE	NB

Date de création	Date de mise à jour	Ind	Création	Visa	Approbation	Visa
28/06/2016	05/09/2016	00	PC			

Ce plan est notre propriété et ne peut être communiqué sans notre autorisation écrite

Plan de Pièce 01460 Montreal La Cluse  
 Tél : 04 74 76 12 66 Fax : 04 74 76 27 67  
 DAQ.331002 **GAGGIONE**

**LLC76x7**  
 Silicone Optics by **GAGGIONE**

FICHER DAO	
ECHELLE	PLANCHE
1	1

**X72801**

D C 1 B A